

→  
Door edge

- 1 Tape the template to the **outside** of the door, aligned with the centerlines.
  - 2 Drill all applicable holes completely through the door (note the exception for the cylinder hole with a mortise device).
- Note:** Drill holes through device shim if using one.

**ONLY FOR PRECISION 2300 SERIES EXIT DEVICES:**  
Door sensing switch mounting hole

Battery bracket hole

Battery bracket/harness hole

**ONLY FOR PRECISION 2100 SERIES EXIT DEVICES :** Door sensing switch mounting hole & channel

Escutcheon mounting holes (4 places)

Align to the Precision Hardware lock stile case 'A' holes.

Cylinder hole

For mortise exit devices, drill this hole into the mortise cavity only, **not** through the door.

**ONLY FOR PRECISION 2200, 2700, and 2800 SERIES EXIT DEVICES :** Door sensing switch mounting hole & channel

Lift finger slot

Aligns to the Precision lock stile case 'C' hole.

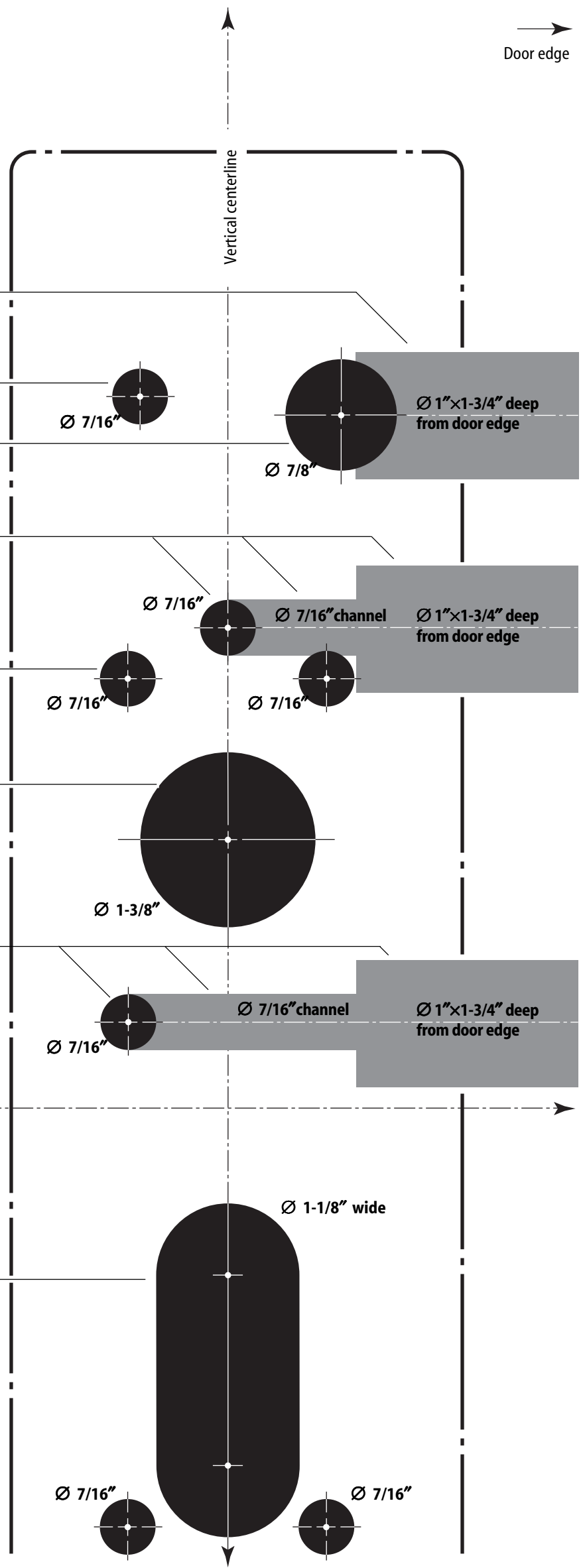
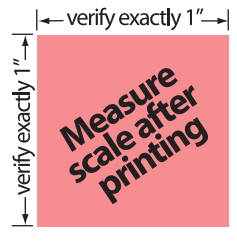

**Use with Precision LHRB applications only**

Title Installation Template for Wi-Q™ Technology EXQ Exit Hardware Trim for Use with Precision Hardware 2000 Series Exit Devices				<b>BEST ACCESS SYSTEMS</b>		
Series EXQ	Backset NA	Trim style MS, PH, PM, DV	Door thickness 1 3/4"–2 1/4"	Rev date 12 /2008	Template number <b>Q08</b>	Rev <b>B</b>

**Note:** To ensure accurate door preparation, use only factory-originated templates. Do not use copies or facsimiles.

T82608 Rev B 3108596 ER-7991-30 Dec 2008

Door edge

Vertical centerline

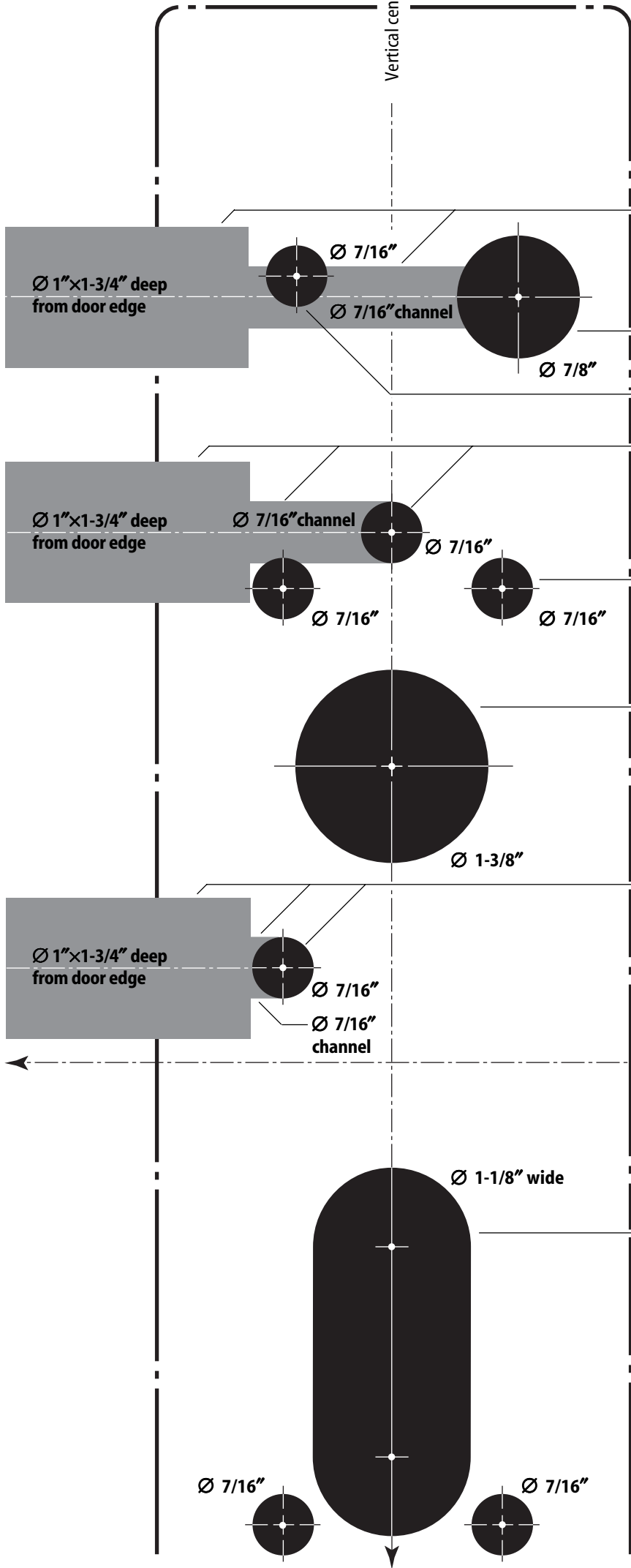

- 1 Tape the template to the **outside** of the door, aligned with the centerlines.
  - 2 Drill all applicable holes completely through the door (note the exception for the cylinder hole with a mortise device).
- Note:** Drill holes through device shim if using one.

**ONLY FOR PRECISION 2300 SERIES EXIT DEVICES:**  
**Door sensing switch mounting hole & channel**

**Battery bracket/harness hole**

**Battery bracket hole**

**ONLY FOR PRECISION 2100 SERIES EXIT DEVICES :** Door sensing switch mounting hole & channel

**Escutcheon mounting holes (4 places)**

Align to the Precision Hardware lock stile case 'A' holes.

**Cylinder hole**

For mortise exit devices, drill this hole into the mortise cavity only, **not** through the door.

**ONLY FOR PRECISION 2200, 2700, and 2800 SERIES EXIT DEVICES :** Door sensing switch mounting hole & channel

To hinge

Horizontal centerline

**Lift finger slot**

Aligns to the Precision lock stile case 'C' hole.

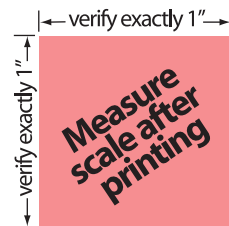

**Use with Precision RHRB applications only**